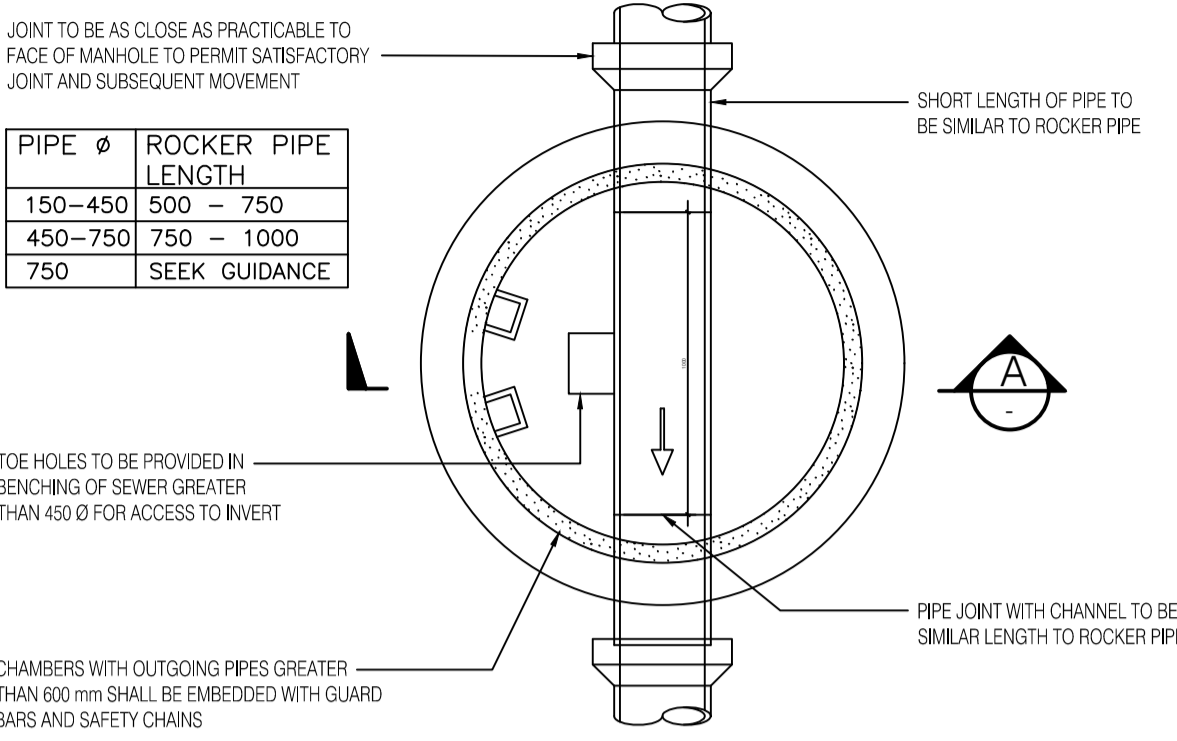

**TABLE 1**

CHAMBER COVERS AND FRAMES TO BE:

a) SQUARE DUCTILE IRON WITH 600 mm CLEAR OPE, CLASS D400 TO I.S. EN 124 1994 BENEATH CARRIAGEWAYS, DRIVEWAYS AND FOOTWAYS.

b) SQUARE DUCTILE IRON WITH 600 mm CLEAR OPE, CLASS B125 TO I.S. EN 124 1994 BENEATH GRASSED AREAS.



**PLAN**  
SCALE 1:25

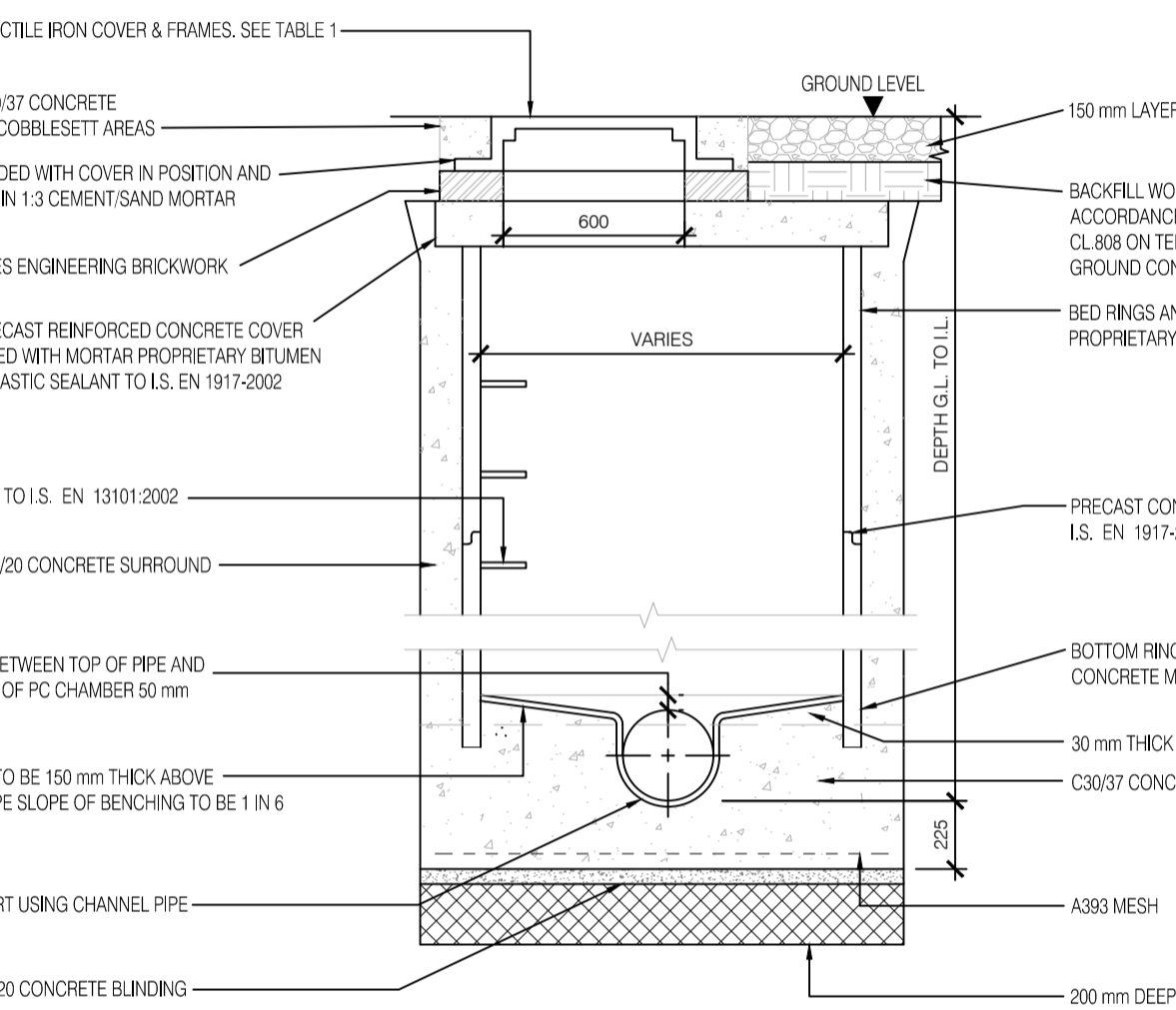

**SECTION A**  
SCALE 1:25

**PRECAST RING MANHOLE, DEPTH TO SOFFIT 0-3 m**  
SCALE 1:25

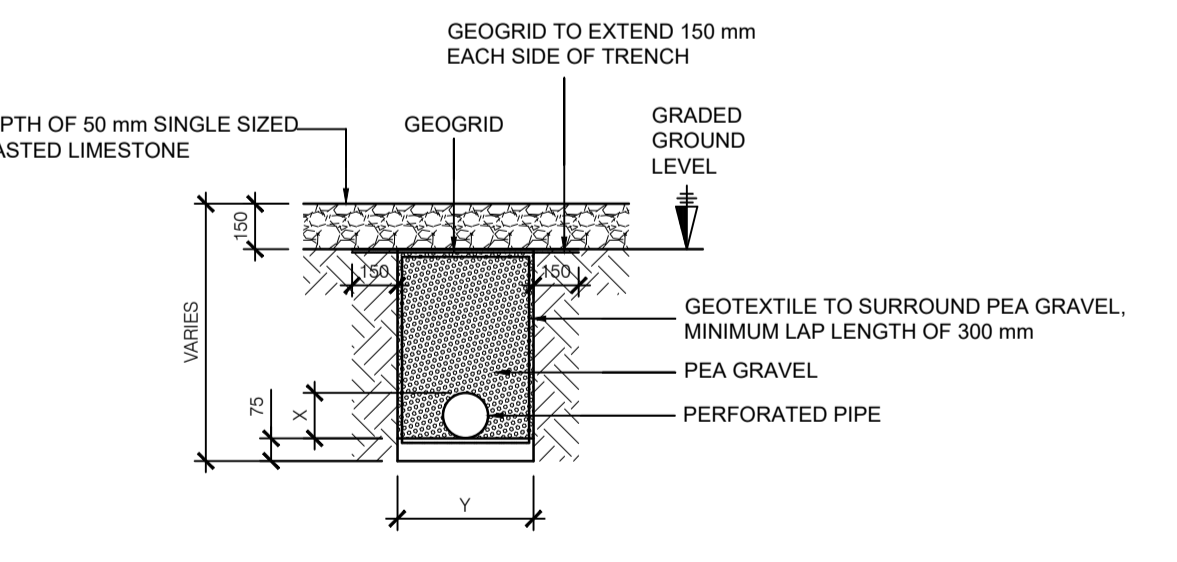

**SECTION THROUGH LAND DRAIN**  
SCALE 1:25

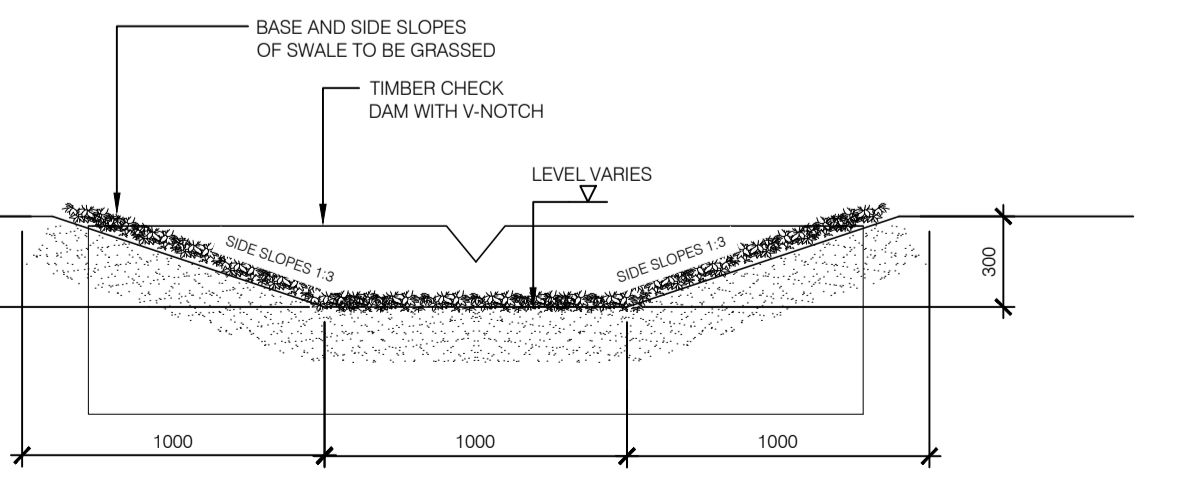

**SECTION THROUGH SITE SWALE**  
SCALE 1:25

**TABLE 2**

TRENCH WIDTH FOR uPVC SEWERS

NOMINAL PIPE SIZE (mm)	WIDTH OF TRENCH (mm)	
	MINIMUM	MAXIMUM
110	450	600
160	450	600
200	600	700
225	600	700
250	600	700
315	700	850
355	750	900
400	800	950
450	850	1000

150 mm LAYER OF COMPOUND STONE OR OTHER SURFACING AS SPECIFIED

GROUND LEVEL

GRANULAR BACKFILL MATERIAL TO CLAUSE 804

INSITU CONCRETE GRADE C16/20, BED & HAUNCH WITH FLEXIBLE COMPRESSIBLE FILLERBOARD AT PIPE JOINT LOCATIONS POLYETHYLENE SHEETING SURROUND TO PIPE.

PIPE DIA. (SEE TABLE 2)

COVER = 1200 mm MINIMUM 450 mm

REFER TO TABLE 2

**SECTION - uPVC DRAINS/SEWERS IN TRAFFIC AREAS (BEDDING CLASS C)**  
SCALE 1:25

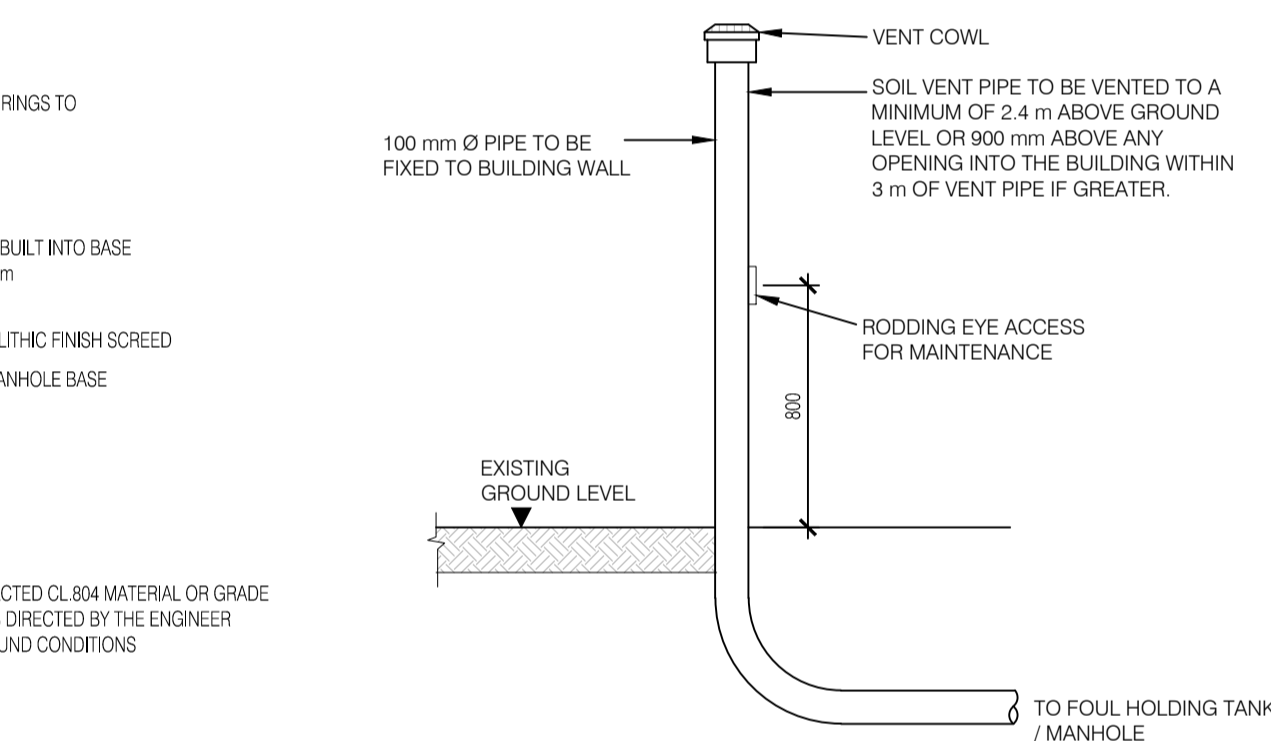

**SOIL VENT PIPE DETAIL**  
SCALE 1:25

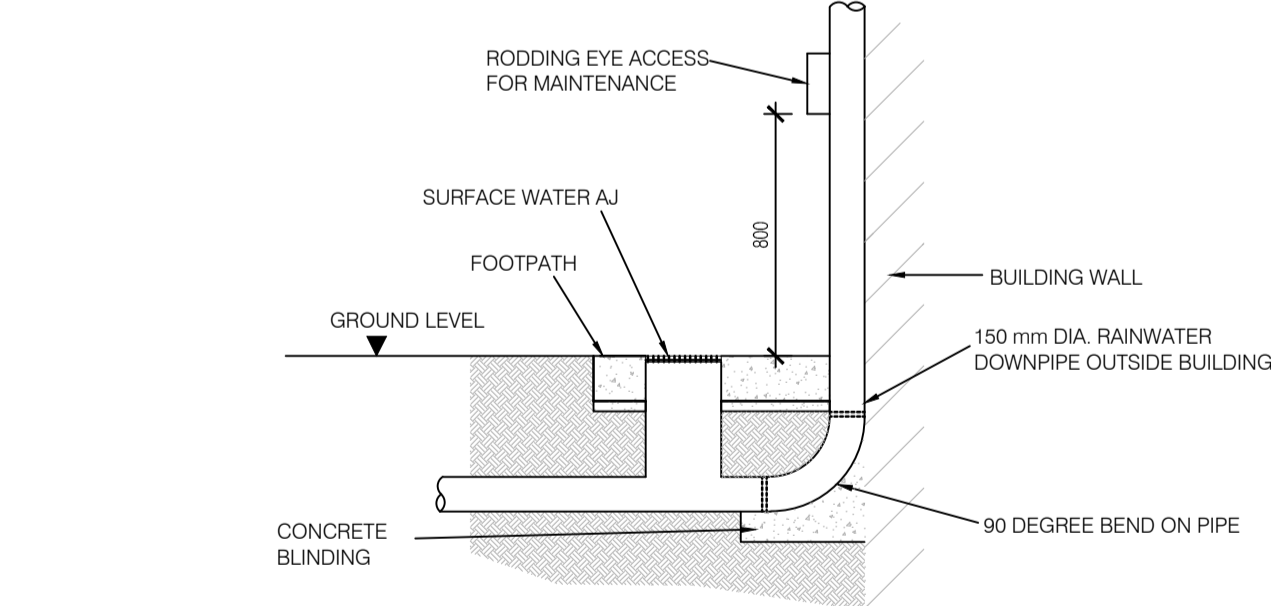

**RAINWATER DOWNPIPE DETAIL**  
SCALE 1:25

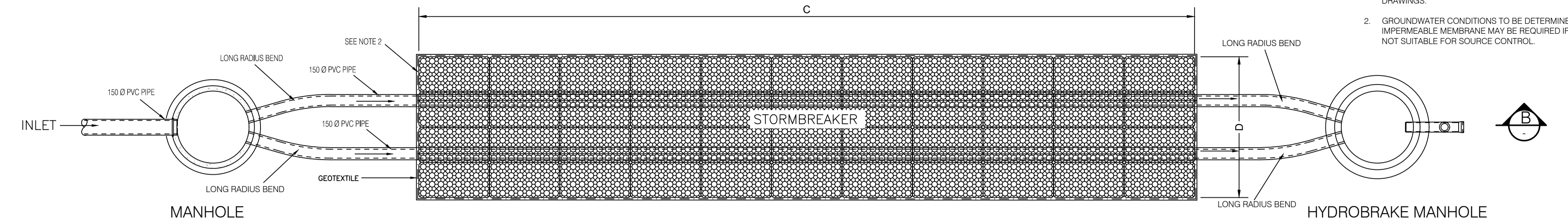

**PLAN OF STORMWATER ATTENUATION SYSTEM ARRANGEMENT**  
SCALE 1:50

**STORMBREAKER DIMENSIONS**

A	COVER TO TANK, MIN. 600 mm
B	DEPTH OF TANK, UNIT DEPTH 165 mm
C	LENGTH OF TANK, UNIT LENGTH 1160 mm
D	WIDTH OF TANK, UNIT WIDTH 580 mm

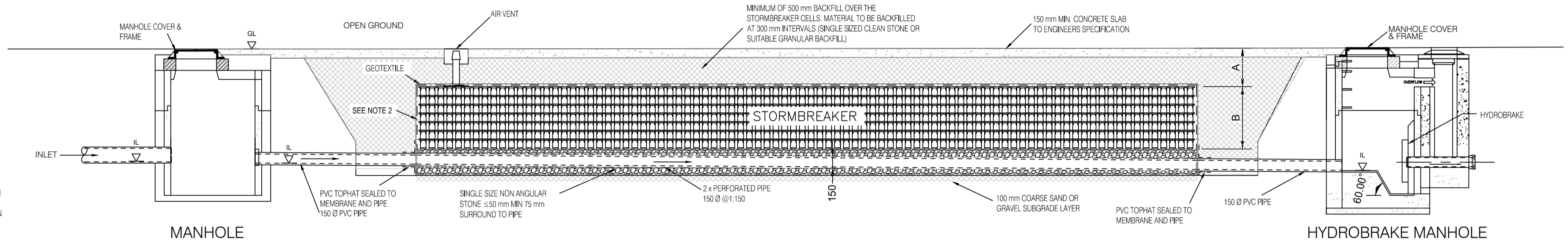

**SECTION B**  
SCALE 1:50

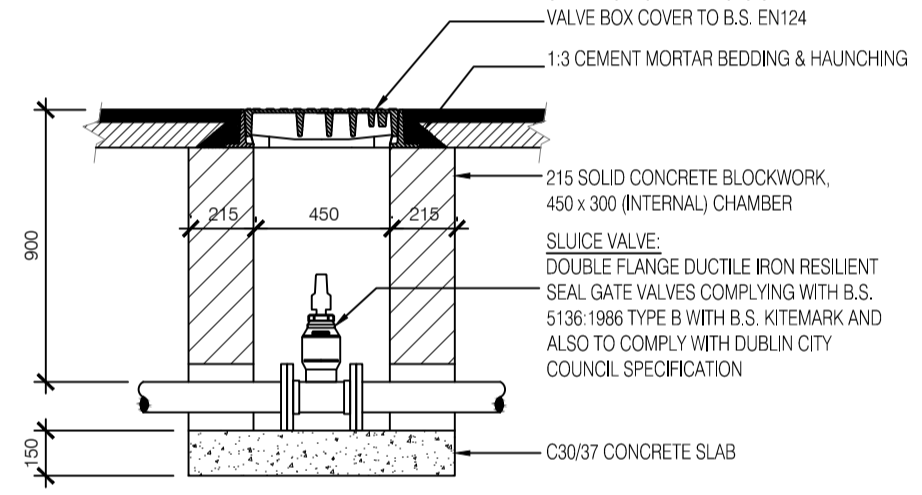

**SLUICE VALVE CHAMBER**  
SCALE 1:25

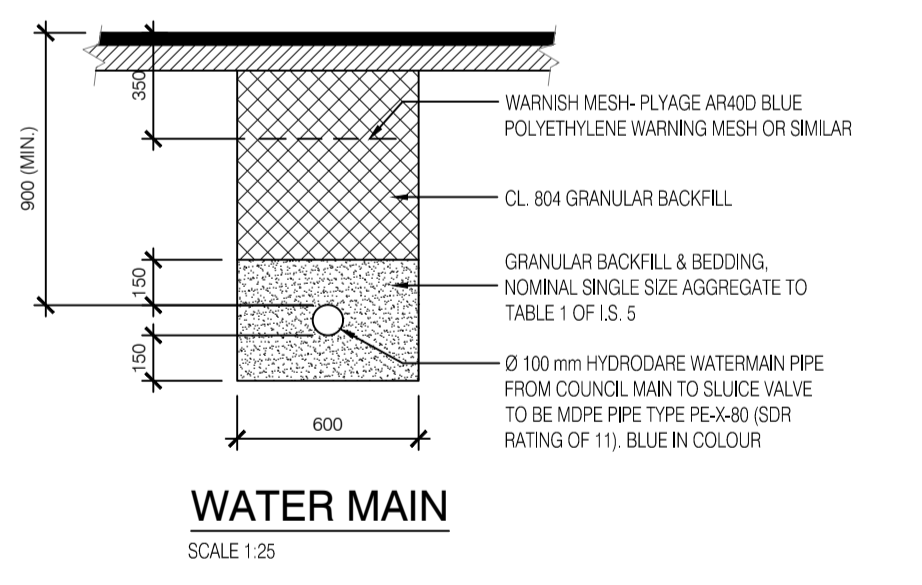

**WATER MAIN**  
SCALE 1:25

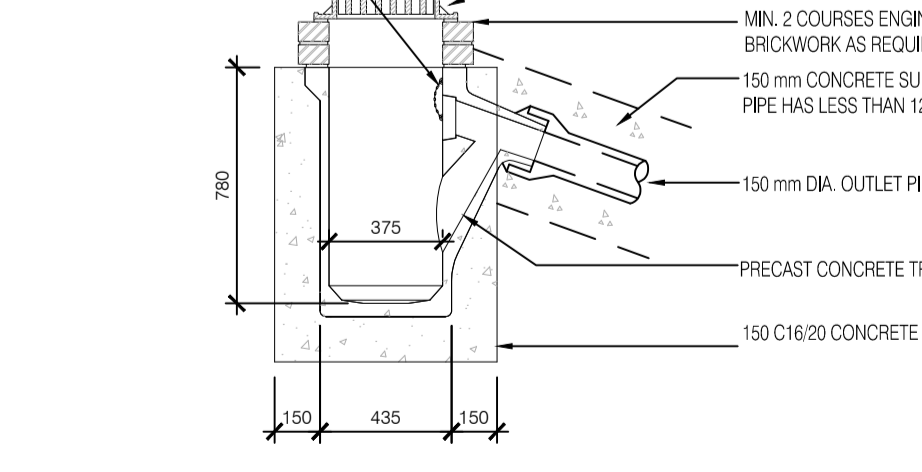

**PRECAST CONC. TRAPPED ROAD GULLY**  
SCALE 1:25

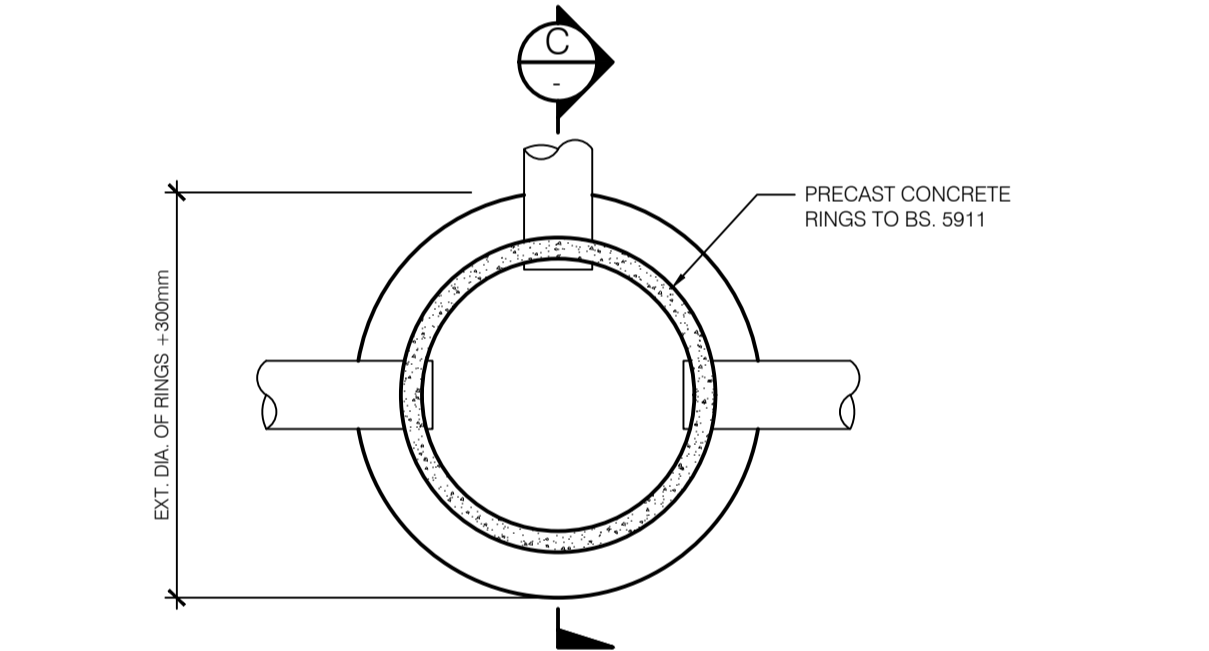

**PRECAST CATCHPIT PLAN**  
SCALE 1:25

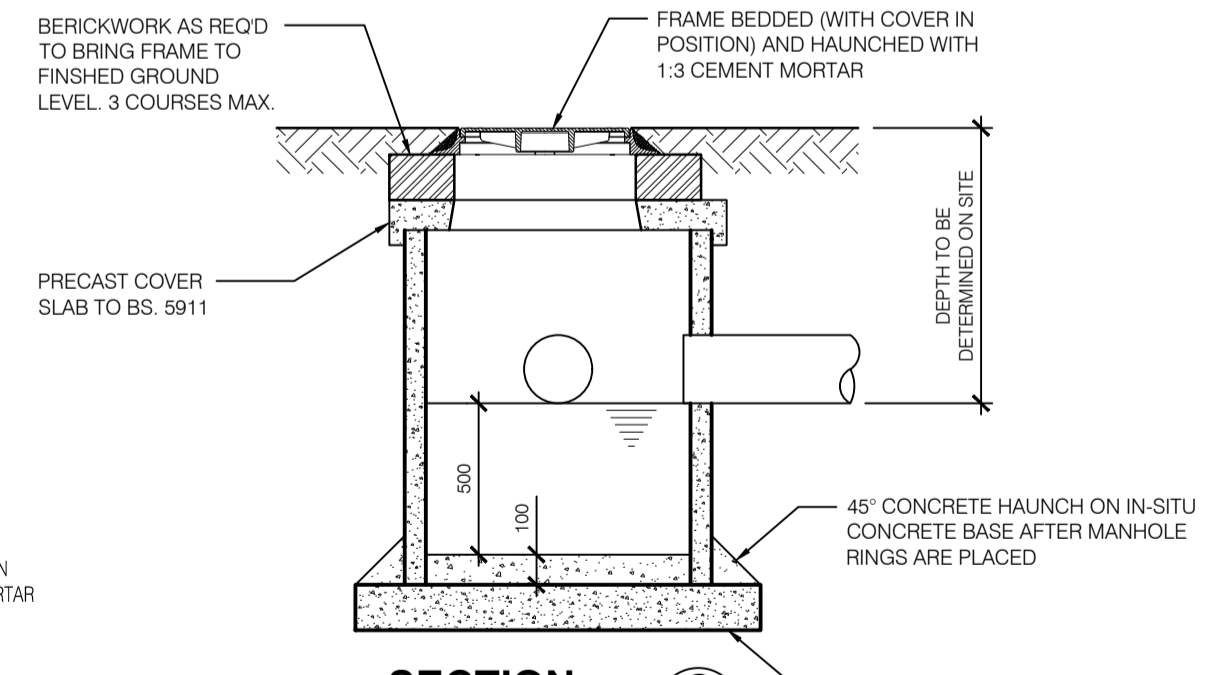

**SECTION C**  
SCALE 1:25

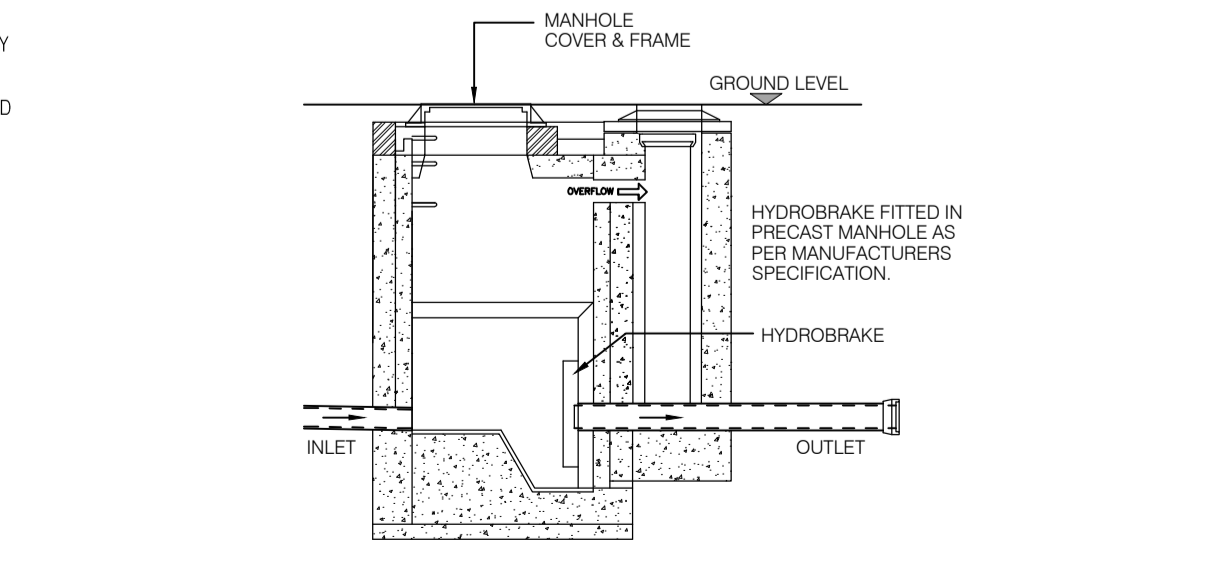

**HYDROBRAKE MANHOLE**  
SCALE 1:50

- NOTES:**
- ALL DIMENSIONS ARE IN mm. NO DIMENSIONS SHALL BE SCALED FROM THE DRAWINGS.
  - GROUNDWATER CONDITIONS TO BE DETERMINED AT DETAILED DESIGN STAGE. IMPERMEABLE MEMBRANE MAY BE REQUIRED IF GROUNDWATER CONDITIONS ARE NOT SUITABLE FOR SOURCE CONTROL.

REV	DATE	REVISION DESCRIPTION	DRN	PROD	VER	APP
2	21.02.24	PROJECT TITLE REVISED, DETAILS ADDED	SB	HG	MY	MH
1	21.08.23	PRODUCTION UNIT REVISED, NOTES AMENDED	SB	AK	HG	MH
0	16.12.20	INITIAL VERSION	RK	AK	HG	RMCG

COPYRIGHT © ESB  
ALL RIGHTS RESERVED. NO PART OF THIS WORK MAY BE MODIFIED, REPRODUCED OR COPIED IN ANY FORM OR BY ANY MEANS - GRAPHIC, ELECTRONIC OR MECHANICAL, INCLUDING PHOTOCOPYING, RECORDING, TAPING OR USED FOR ANY PURPOSE OTHER THAN ITS DESIGNATED PURPOSE, WITHOUT THE WRITTEN PERMISSION OF ESB.

PURPOSE OF ISSUE - PRELIMINARY UNLESS INDICATED

CLIENT APPROVAL  PLANNING  TENDER  CONSTRUCTION  AS-BUILT

CLIENT: Oriel Windfarm Limited

PROJECT: Oriel Wind Farm Project

CONTRACT:

DRAWING TITLE: ONSHORE SUBSTATION PROPOSED DRAINAGE DETAILS

PRODUCTION UNIT: Civil, Environmental and Renewable Engineering

Engineering and Major Projects,  
One Dublin Airport Central, Dublin Airport,  
Cloghan, Co. Dublin, K67 XF72, Ireland.  
Tel: +353 (0)1 703 8000 Web: www.esb.ie  
Engineering and Major Projects is a division of ESB.

DRAWN	PRODUCED	VERIFIED	APPROVED	APPROVAL DATE
S.Bolton	H.Griffin	M.Vaughan	M.Hogan	23/02/2024
CLIENT REF	NO. OF SHTS	SIZE	SCALE	
TC223815	1	A1	1:25 / 1:50	

DRAWING NUMBER: PE605-D027-038-015-002